

---

**NAVAIR**

---

INTERNATIONAL PVT. LTD.

---

Door Type	Steel Fire Rated Door
Criteria	Stability & Integrity with Infill Insulation Material
Rating	120 mins
Shutter Thickness	49 mm
Testing Standards	BS 476 Part 20 - 22, IS 3614 Part 2
Test Laboratory	CBRI Roorkee, India

## CONSTRUCTION DETAILS

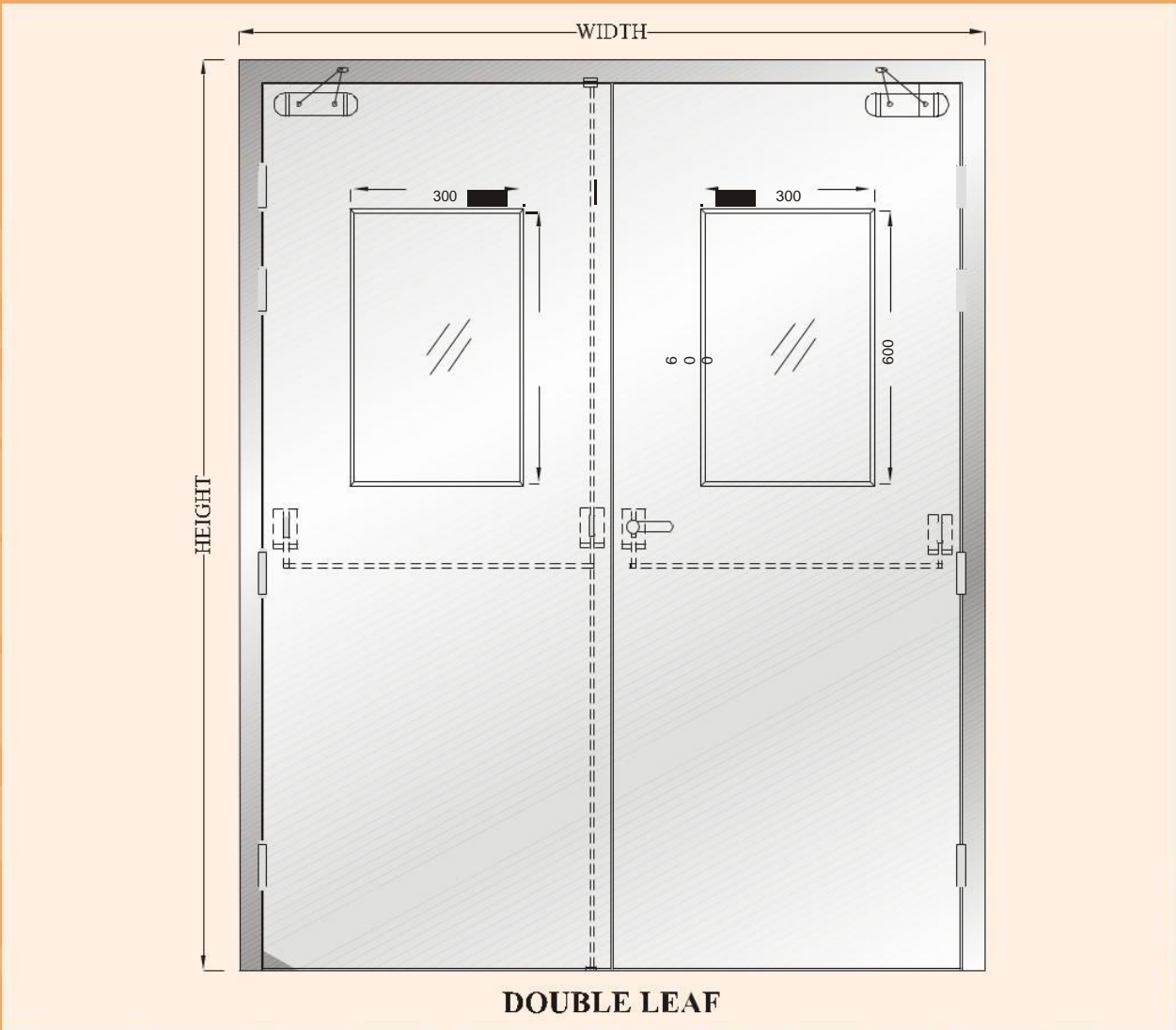

### Detail Description

- 1 Steel frame Profile Design - NDRF 154 x 77
- 2 Frame manufactured with 1.5mm Galvanised Steel
- 3 Shutter Thickness - 49mm
- 4 Shutter Honey Comb / Wool Insulation Infill treated with VIPER FRS 881 LH
- 5 Shutter manufactured with 1.0mm Galvanised Steel
- 6 Tested with Vision Panel for 120 minutes rating

*Note: Navair is having steel frame door 2300 x 2800mm Height (Tested)*

### Recommended Finish

#### Frame & Shutter

- 1.1 Powder Coating in desired RAL Shade Code
- 1.2 Polyurethane Coating in desired RAL Shade Code
- 1.3 Selective Wood Grain Finishes available

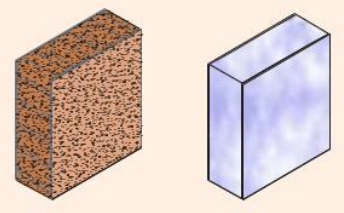
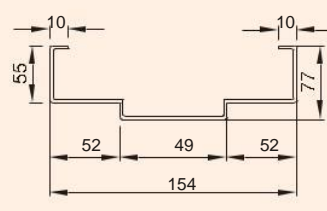
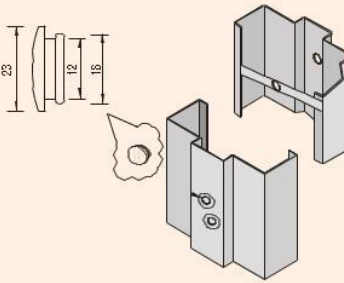
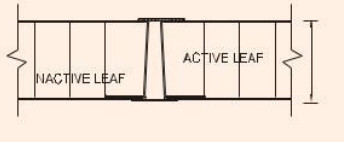
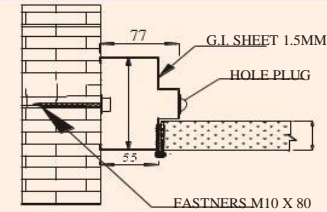
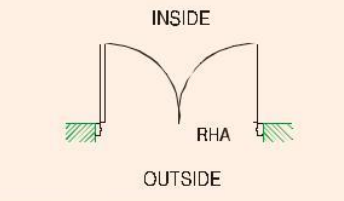
<p><b>INNER FILLING</b></p>  <p>WOOL INSULATION    MINERAL WOOL</p>	<p><b>FRAME SECTION</b></p>  <p>DOUBLE REBATE 1.5MM STEEL FRAME</p>	<p><b>ANCHOR COVER</b></p> 
<p><b>ASTRAGEL DETAIL</b></p> 	<p><b>TYPICAL DETAIL OF JAMB</b></p> 	<p><b>DOOR HANDING</b></p> 

\*The Above sketches are only indicative, actual products may vary.



Door Type	Steel Fire Rated Door
Criteria	Stability & Integrity with Infill Insulation Material
Rating	120 mints
Shutter Thickness	46 mm
Testing Standards	BS 476 Part 20 - 22, IS 3614 Part 2
Test Laboratory	CBRI Roorkee, India

## CONSTRUCTION DETAILS

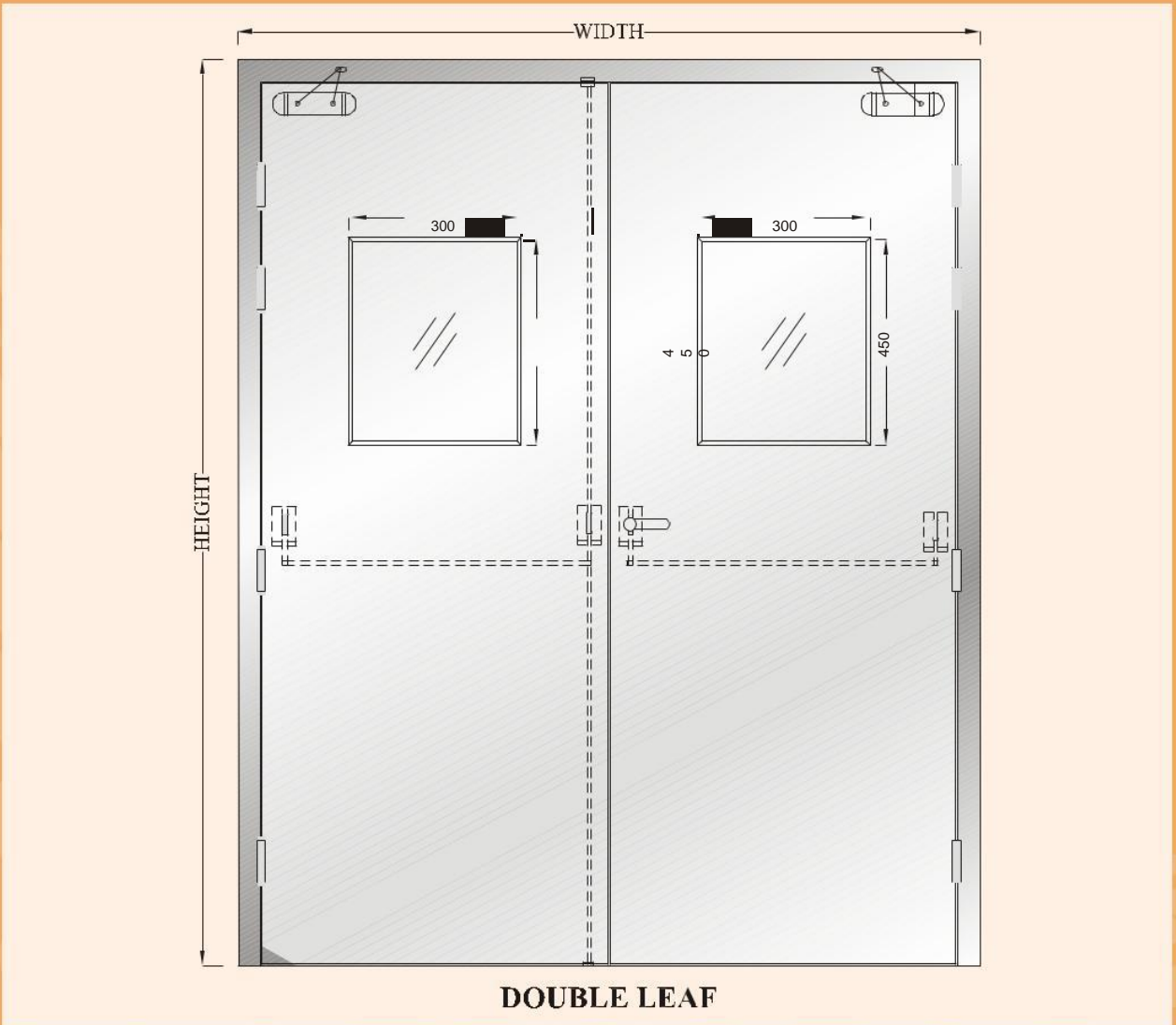

### Detail Description

- 1 Steel frame Profile Design - NDRF 100 x 57mm
- 2 Frame manufactured with 1.2mm Galvanised Steel
- 3 Shutter Thickness - 46mm
- 4 Shutter Honey Comb / Wool Insulation Infill treated with VIPER FRS 881 LH
- 5 Shutter manufactured with 0.8mm Galvanised Steel
- 6 Tested with Vision Panel for 120 minutes Fire Rated

### Recommended Finish

#### Frame & Shutter

- 1.1 Powder Coating in desired RAL Shade Code
- 1.2 Polyurethane Coating in desired RAL Shade Code
- 1.3 Selective Wood Grain Finishes available

INNER FILLING

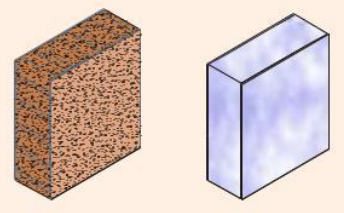

WOOL INSULATION MINERAL WOOL

FRAME SECTION

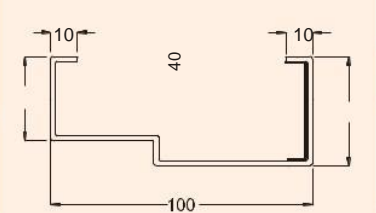

ANCHOR COVER

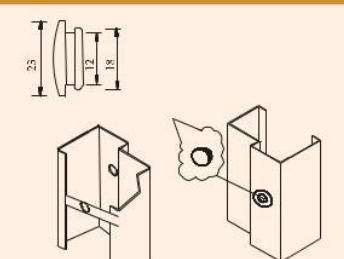

ASTRAGEL DETAIL

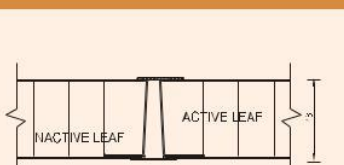

FRAME & SHUTTER SECTION

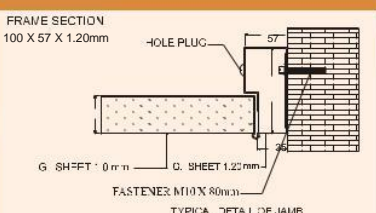

DOOR HANDING

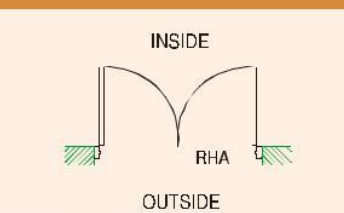

\*The Above sketches are only indicative, actual products may vary.





Indian Green Building Council



केंद्रीय भवन अनुसंधान संस्थान, रुद्रकी  
CENTRAL BUILDING RESEARCH INSTITUTE, ROORKEE  
(A Constituent Establishment of CSIR)



Corporate Office:

**Navair International Pvt. Ltd.**

59/17 Guru Ravidas Marg, 2nd Floor, Kalkaji Extn, New Delhi

 +91-11-46865000

 [marketing@navairindia.com](mailto:marketing@navairindia.com)  
[info@navairindia.com](mailto:info@navairindia.com)



Website: [www.navairindia.com](http://www.navairindia.com)