

NAVAIR

INTERNATIONAL PVT. LTD.

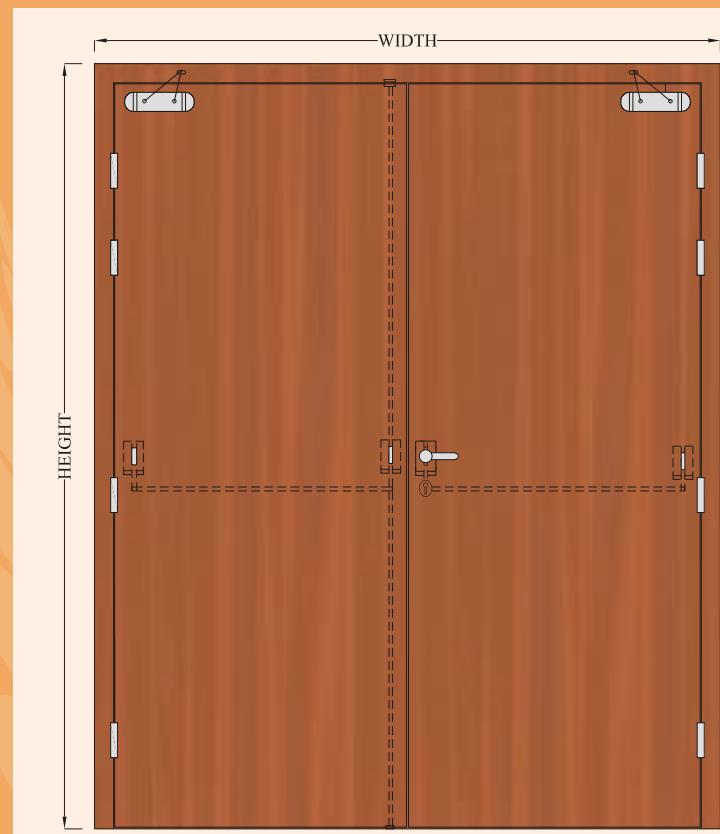

Astragal Seal for Double Door

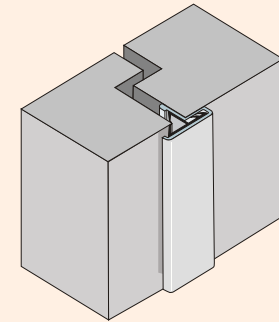

Parameter Seal for Frame

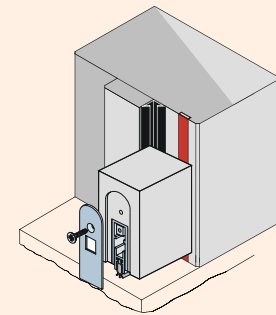

External Parameter Seal

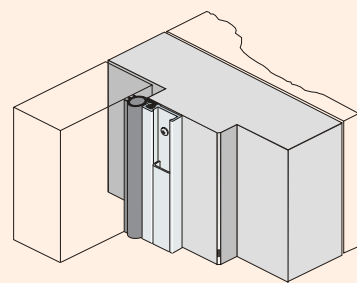

Mortise Drop Down Seal

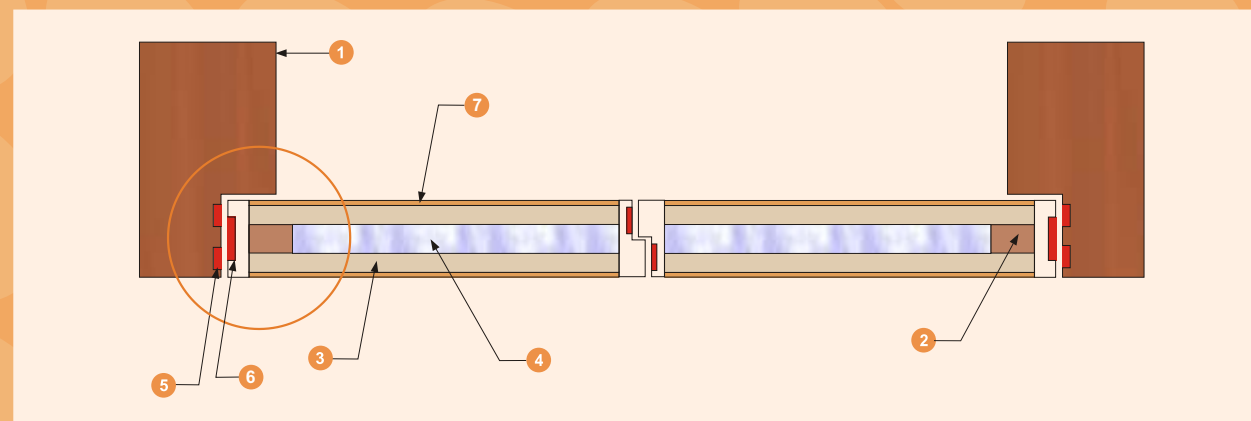
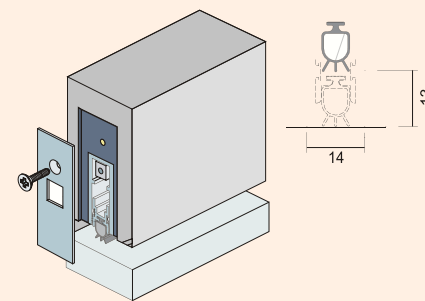

Door Type	Wooden Fire Rated Cum Acoustic Door
Criteria	3 Criteria : Fully Insulated
Rating	Up to 120 mins
Acoustic Rating	32 dB approximately (can be enhanced by putting external Peremeter Seal)
Shutter Thickness	77 mm (Normal)
Testing Standards	BS 476 Part 20 - 22, IS 3614 Part 2
Test Laboratory	CBRI Roorkee, India. For wooden fire design

CONSTRUCTION DETAILS

Detail Description

- 1 Frame Manufactured out of Hardwood Mirandi / Teakwood of nominal section 140mm x 90mm
- 2 Hardwood Internal Timber Framework
- 3 Calcium Silicate Board
- 4 Shutter infill insulation - Wool insulation infill treated with VIPER FRS 881 LH
- 5 Intumescent Seal Size - 10mm x 4mm - 2 Nos for frame
- 6 Intumescent Seal Size - 20mm x 4mm - 1 No for door shutter
- 7 Both side 3mm Commercial Ply

Recommended Finishes

1 Frame

- 1.1 Hardwood: VIPER Fire Retardant Primer FR 880 with VIPER Finishing Paint FRS 881
- 1.2 Teakwood: VIPER Fire Retardant Clear Polish FR881 Clear

2 Door Shutter

- 2.1 Painting with VIPER Fire Retardant Primer FR 880 with VIPER Finishing Paint FRS 881 - both sides
- 2.2 One side laminate / veneer and one side painting with VIPER Fire Retardant Primer FR 880 with VIPER Finishing Paint FRS 881
- 2.3 Both Sides Laminate / Veneer

*The Above sketches are only indicative, actual products may vary.





Indian Green Building Council



केंद्रीय भवन अनुसंधान संस्थान, रुद्रकी
CENTRAL BUILDING RESEARCH INSTITUTE, ROORKEE
(A Constituent Establishment of CSIR)



Corporate Office:

Navair International Pvt. Ltd.

59/17 Guru Ravidas Marg, 2nd Floor, Kalkaji Extn, New Delhi

 +91-11-46865000

 marketing@navairindia.com
info@navairindia.com



Website: www.navairindia.com