

NAVAIR

INTERNATIONAL PVT. LTD.

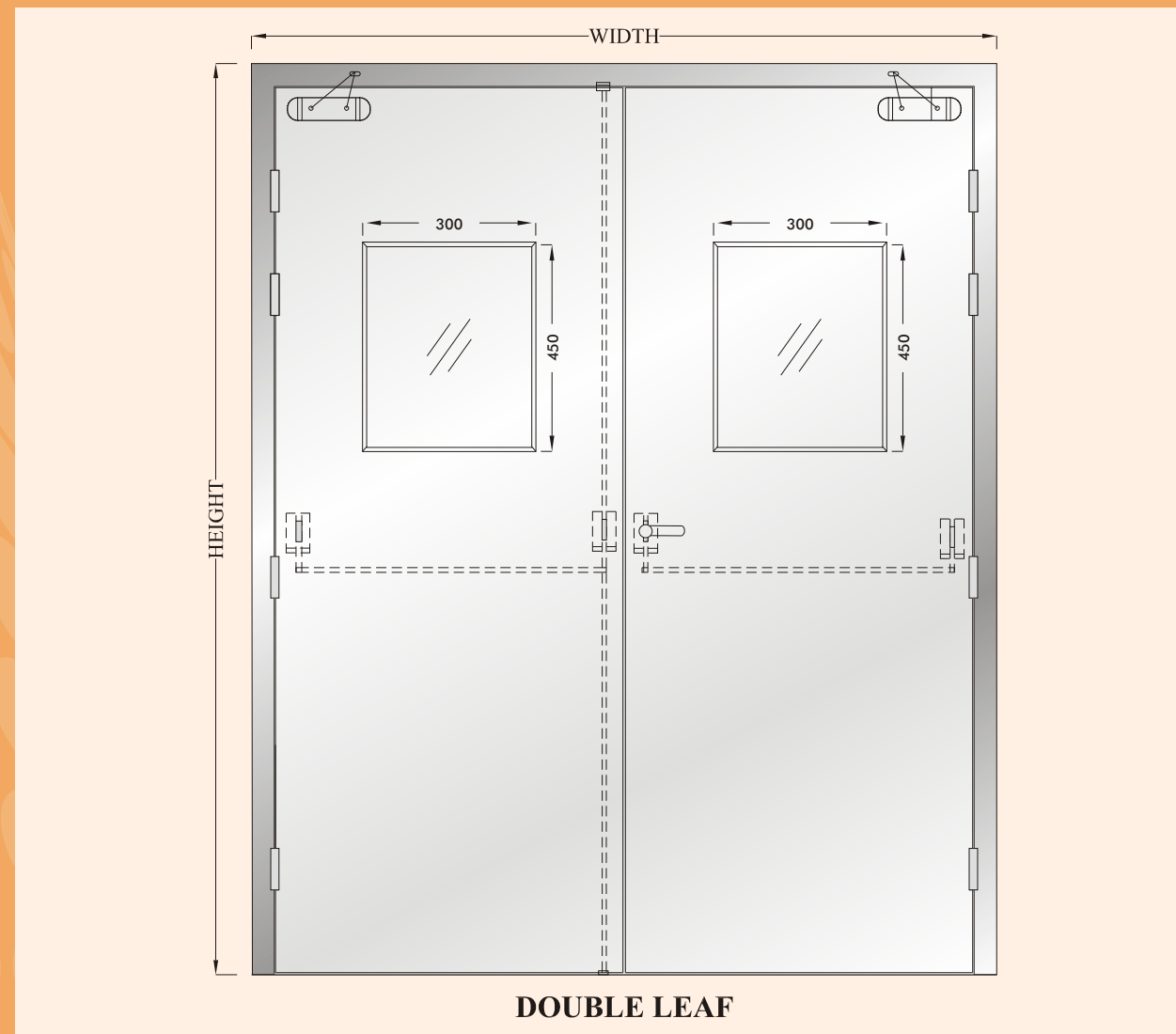

Door Type	Steel Fire Rated Door
Criteria	Stability & Integrity with Infill Insulation Material
Rating	120 mints
Shutter Thickness	46 mm
Testing Standards	BS 476 Part 20 - 22, IS 3614 Part 2
Test Laboratory	CBRI Roorkee, India

CONSTRUCTION DETAILS

Detail Description

- 1 Steel frame Profile Design - NDRF 100 x 57mm
- 2 Frame manufactured with 1.2mm Galvanised Steel
- 3 Shutter Thickness - 46mm
- 4 Shutter Honey Comb / Wool Insulation Infill treated with VIPER FRS 881 LH
- 5 Shutter manufactured with 0.8mm Galvanised Steel
- 6 Tested with Vision Panel for 120 minutes Fire Rated

Recommended Finish

Frame & Shutter

- 1.1 Powder Coating in desired RAL Shade Code
- 1.2 Polyurethane Coating in desired RAL Shade Code
- 1.3 Selective Wood Grain Finishes available

INNER FILLING

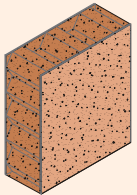
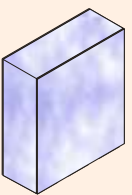
WOOL INSULATION

MINERAL WOOL

FRAME SECTION

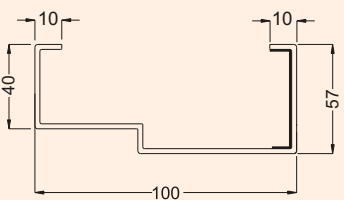

ANCHOR COVER

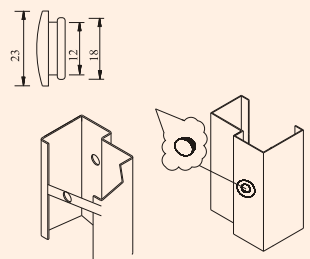

ASTRAGEL DETAIL

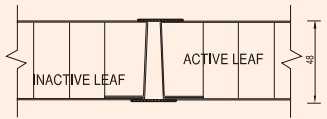

FRAME & SHUTTER SECTION

FRAME SECTION
100 X 57 X 1.20mm

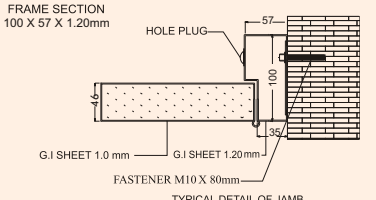

HOLE PLUG

G.I. SHEET 1.0 mm

G.I. SHEET 1.20mm

FASTENER M10 X 80mm

TYPICAL DETAIL OF JAMB

DOOR HANDING

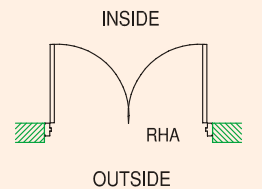

INSIDE

RHA

OUTSIDE

*The Above sketches are only indicative, actual products may vary.





Indian Green Building Council



केंद्रीय भवन अनुसंधान संस्थान, रुद्रकी
CENTRAL BUILDING RESEARCH INSTITUTE, ROORKEE
(A Constituent Establishment of CSIR)



Corporate Office:

Navair International Pvt. Ltd.

59/17 Guru Ravidas Marg, 2nd Floor, Kalkaji Extn, New Delhi

 +91-11-46865000

 marketing@navairindia.com
info@navairindia.com



Website: www.navairindia.com